

PITOBAR

Averaging Pitot Tube for flow measurement

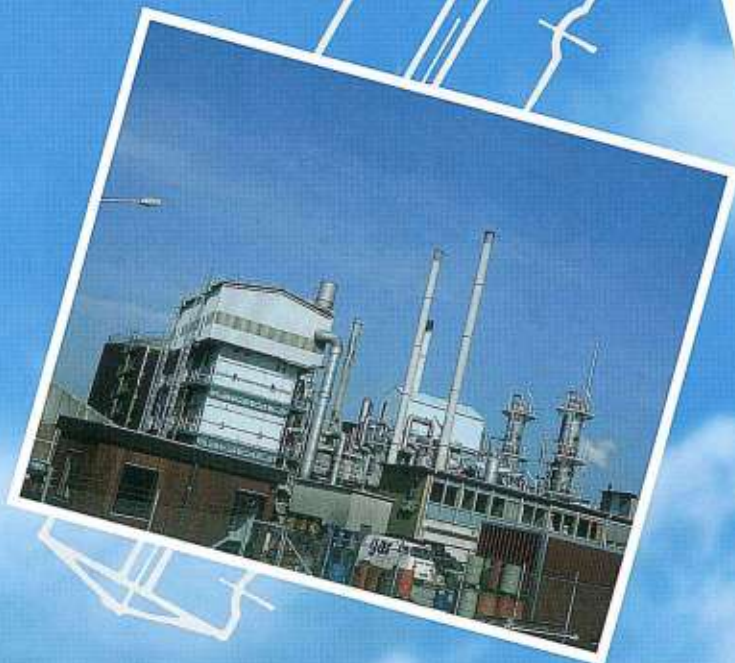

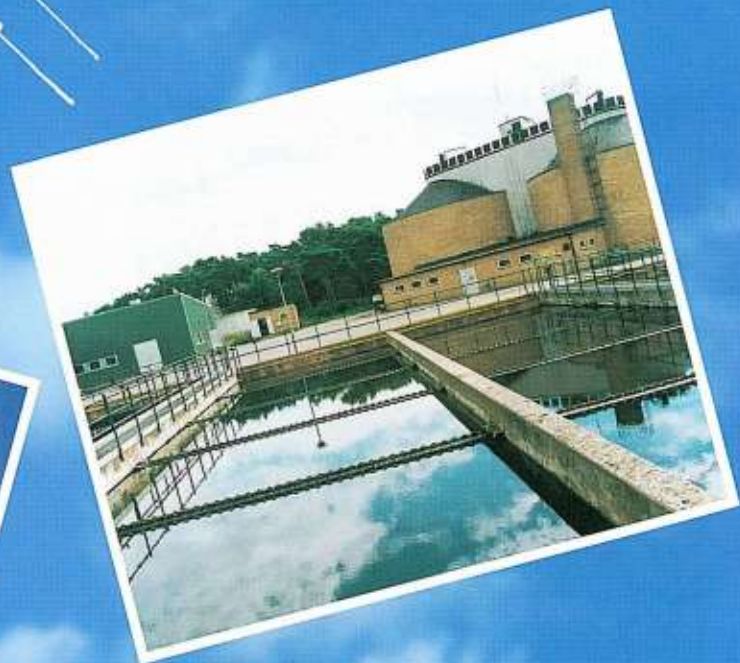

Company

EMCO Controls is a Danish instrumentation company.

The factory is placed in Hørsholm near Copenhagen, not far from Hamlet's Elsinore.

From the premises in Hørsholm, domestic and export sales as well as manufacturing are conducted. We employ skilled people with many years of experience in manufacturing of primary elements.

EMCO Controls originates back to 1966 and has right from the beginning been recognized as a manufacturer of primary elements for flow measurement.

A quality system, based upon ISO 9001, has been introduced in order to manufacture according to a quality defined by international standards, by our customers or by ourselves.



Engineering

Design and engineering of our instruments are based on recognized international standards including DIN, TRD, VDE/VDI and ASME. Our work is supported by CAD and computer programmes developed by our engineers.

We continually strive to provide high quality sensors with design innovations to meet our customers' requirements.

Manufacturing

We stock raw material with traceable material certificates acc. to EN 10204 - 3.1B, 3.1C - or 3.1A.

Weldings are done by qualified welders according to ASME IX or EN standards.

The instruments can be non destructive examined NDE according to ASME or EN standards. Heat treatment of the flow sensors is available to comply to NACE MR-01-75.



PITOBAR Averaging Pitot Tube

Application

The PITOBAR Averaging Pitot Tube is used for flow measurement of liquids, gases and steam in circular or rectangular pipes or ducts.

PITOBARS are installed in power stations, petrochemical and chemical industry, pollution control, water processing industry, refineries and steel processing industry, just to name a few.

The PITOBAR Averaging Pitot Tube principle of operation is derived from the classic or single point pitot tube, which has been used for flow measurement for many decades.

The single point pitot tube is manually moved up and down inside the pipe or



duct to measure the flow (dynamic pressure). As opposed to this, the PITOBAR averaging pitot tube has a number of holes depending on pipe size pointing towards the up-stream side. One port pointing down stream measures the static pressure.

The fluid must be in one phase and the pipe shall be run full in the measuring section. Changes of flow shall be slowly i.e. without pulsations.

The PITOBAR has very low installation costs and the pressure loss is low compared to other flow elements, especially in larger pipe sizes.

Construction and Design

The PITOBAR Averaging Pitot Tube is constructed and designed with a diamond shaped strut with several ports spaced centrally within concentric rings of equal area pointing towards the upstream side. This is done in order to get the best averaging measurement of the dynamic pressure, resulting in a more accurate flow reading.

The pitot tube creates a differential pressure signal which is proportional to the flow rate in accordance with the law of Bernoulli.

Differential Pressure = (Pstatic + Pdynamic) - Pstatic

There is a square root relationship between flow and differential pressure.

$$Q = A \cdot k \sqrt{\frac{P_d}{1/2 \cdot \rho}}$$

P_d = dynamic pressure, ρ = density,

k = constant, A = Area, Q = flow

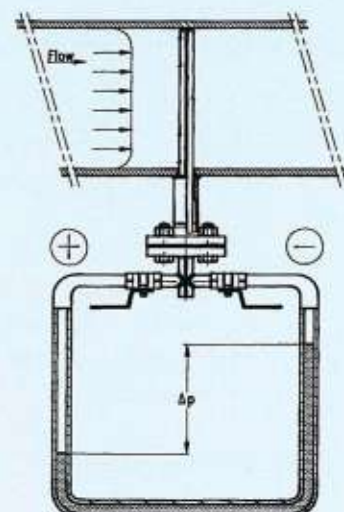
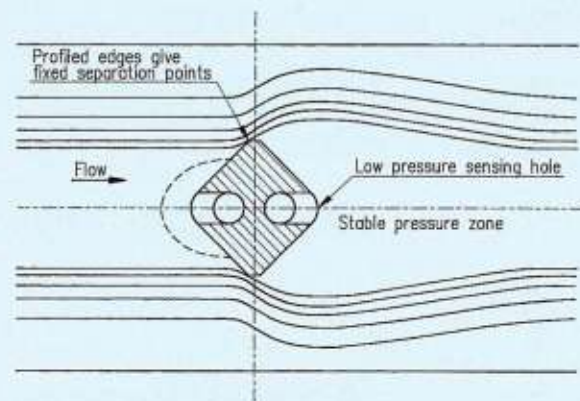

Technical Specifications

Sizes :	DN 50 - DN 8000, 2" - 320"
Pressure rating :	PN 16 - 400, 150 - 2500 lbs, ISO PN 20, 50, 100, 150, 250, 420
Temperature range :	-100 °C - +900 °C
Material :	- Stainless steel - CrMo steel - Hastelloy C - Inconel - Monel - Titanium - PVDF - others on request
Process Connections:	Flange according to pressure rating. All welded construction
Flange Standards :	DIN, ANSI, ISO, others on request
Mounting :	Welding to pipe
Accuracy :	±1% accuracy of actual flow
Repeatability :	±0,1%
Reynolds no.:	Minimum 100.000 of full flow
Rangeability :	10:1
Max. differential pressure :	Depending on type, size and fluid (density, velocity)
Max. fluid velocity :	See "Frequency calculation"
Probe sizes:	DK20*: 20 x 20 mm DK25*: 25 x 25 mm PC45*, PC55*: 45 x 45 mm
Special applications :	Purge connections, if required. All welded construction for high pressure and temperature of steam flow.

* Last digit gives the type i.e. DK202

Differential Pressure Calculation

The differential pressure is calculated using the equations listed below. A PC calculation programme is obtainable from EMCO Controls.

Liquid (Volumetric flow m³/h)

$$d_p = \rho * \left(\frac{7,996 * Q}{Z * D^2} \right)^2$$

Gas (Volumetric flow Nm³/h)

$$d_p = \frac{\rho * T}{P} * \left(\frac{4,8723 * Q}{Z * D^2} \right)^2$$

Liquid, gas and steam (mass flow kg/h)

$$d_p = \frac{1}{\rho} * \left(\frac{7,996 * Q}{Z * D^2} \right)^2$$

d_p = differential pressure in KPa

ρ = specific gravity (kg/m³ or kg/Nm³)

T = absolute temperature in °K

P = absolute pressure in KPa

Q = flow rate in Nm³/h, m³/h or kg/h

D = inner pipe diameter in mm

Z = flow factor (obtainable from EMCO Controls)

Rangeability

The rangeability of the PITOBAR is determined by the limits of the minimum and maximum flow where the flow factor is constant within a range of Reynolds Nos.

The flow must be turbulent which means a Reynolds No. above 10.000.

The best result is obtained if the Reynolds No. is above 100.000.

$$Re = \frac{V * D}{\gamma}$$

V = Velocity, *D* = Inner pipe diameter, *γ* = kinematic viscosity

The rangeability of the PITOBAR averaging pitot tube is defined as a maximum flow over a minimum flow for a given accuracy.

With one differential pressure transmitter of the SMART type the rangeability will be minimum 10:1 within the given limits for a Reynolds No. with a reasonable accuracy.

The PITOBAR has a diamond shape which gives a defined separation point.

The separation point secures a stable pressure zone around the static pressure hole, ensuring correct static pressure measurement.

Derived from the equation for the differential pressure calculation it is important to measure the static pressure correctly, in order to measure a true differential pressure. Therefore, the flow profile around the probe is of vital importance to the rangeability as well as the accuracy.

Maximum Allowable Differential Pressure

The maximum allowable differential pressure is an indication of which type of PITOBAR to choose in order to avoid bends or cracks. Due to mechanical stress factors the maximum allowable dp should be taken into consideration. If the actual differential pressure exceeds the maximum allowable it is advisable to choose another flow sensor.

Maximum allowable differential pressure in bar, without bottom support, with reference to mechanical bend.

Type	DK200A 1 1/2/3 at 20°C	DK200A 1 1/2/3 at 400°C	DK250A 1 1/2/3 at 20°C	DK250 1 1/2/3 at 400°C	PC450 at 20°C	PC455 at 20°C
Length						
100						
200	3,75	1,81				
300	1,66	0,81	2,52	1,19		
400	0,94	0,45	1,42	0,67		
500	0,60	0,29	0,91	0,43		
600	0,42	0,20	0,63	0,30		
700	0,31	0,15	0,46	0,22		
800	0,23	0,11	0,35	0,17	0,87	
1000	0,15	0,07	0,23	0,11	0,61	0,62
1200			0,16	0,07	0,45	0,43
1400			0,12	0,05	0,34	0,32
1600					0,27	0,24
1800					0,22	0,19
2000						0,16

The critical flow velocity should also be taken into consideration, see section below.

Frequency Calculation

Frequency check is not necessary for liquid flows since max. allowable differential pressure is reached before the limit, due to own frequency.

However, it is for gas and steam necessary to check for the frequency limit. If the PITOBAR tube is used in a zone where the Strouhal frequency and the natural frequency of the pitot tube coincides, there is a possibility that the PITOBAR may vibrate to destruction.

The critical flow velocity must therefore be considered. The critical velocity is depending on the length of the probe equal to the internal pipe diameter.

Velocities between 1st and 2nd order frequency vibrations +/-10% are not critical. Only if the flow velocity coincides with the critical flow velocity for a longer period, there is a risk that the PITOBAR may vibrate to destruction.

The critical flow velocity is inversely proportional to the square root of the length.

For check, please use the equation below. For any doubt choose a sensor with bottom support.

Without bottom support:

type DK200/1/2/3-A, 1st order own frequency.

$$\text{Max } V = \frac{2,46}{D^2}$$

Type DK 250/1/2/3-A, 1st order own frequency.

$$\text{Max } V = \frac{3,95}{D^2}$$

With bottom support:

type DK200/1/2/3-B, equal to 2nd order own frequency.

$$\text{Max } V = \frac{15,67}{D^2}$$

Type DK250/1/2/3-B, equal to 2nd order own frequency.

$$\text{Max } V = \frac{24,83}{D^2}$$

D = inner pipe diameter in M, V = velocity (m/s)

Pressure Loss

The pressure loss varies from 10 % of measured differential pressure in the smaller pipe sizes to less than 2 % in the larger sizes.

Installation Requirements

Certain installation requirements for straight pipe lines must be fulfilled in order to achieve the most accurate flow measurement. See table below.

Required straight pipe lengths

	Up-stream (x D)	Down-stream (x D)
Single 90° bend	9	3
Two or more 90° bends in the same plane	14	3
Two or more 90° bends in different planes	24	4

For more details please see our instruction manual for installation.



PITOBAR Types

DK 200, DK 250



Standard types for liquid and gas flow measurement.

Sizes:
DK 200:
DN 50 - DN 1000, 2" - 40"

DK 250:
DN 100 - DN 2000, 4" - 80"
Pressure rating:
up to PN 400, 2500 lbs

DK 203, DK 253



Flow sensors like type DK 200 and DK 250 but with mounting flange for direct transmitter mounting.

Sizes:
DK203:
DN 50 - DN 1000, 2" - 40"

DK253:
DN 50 - DN 2000, 2" - 80"
Pressure rating:
up to PN 400, 2500 lbs

DK 201, DK 251



Flow sensors including condensing chambers for steam flow measurement.

Sizes:
DK201:
DN 50 - DN 1000, 2" - 40"

DK251:
DN 100 - DN 2000, 4" - 80"
Pressure rating:
up to PN 160, 900 lbs

PC 450, PC 455, PC 550, PC 555



TYPE 450, 455: Flow sensors in heavy duty design for gas and liquid flow measurement in larger pipe sizes.

Sizes :
DN 400 - DN 8000, 16"-320"
Pressure rating:
max. PN 40, 300 lbs, higher pressure rating on request.

TYPE 550, 555: Flow sensors made from PVDF for flow measurement of corrosive liquids and gases.

Sizes:
DN 400 - DN 2000, 16" - 80"
Pressure rating:
PN 16, 150 lbs

DK 202, DK 252



The instruments are retractable from the process under pressure.

Sizes:
DN 100 - DN 1500, 4" - 60"
Pressure rating :
up to PN 100, 600 lbs

DK 261



Flow sensor especially developed for steam and live steam flow measurement at high pressure and temperature. Type DK 261 is recommended for pressure above 80 bar.

All welded construction including condensing chambers.
Sizes:
DN 100 - DN 500, 4" - 20"
temp.: max. 580 °C
pressure: max. 300 bar

Mounting installations

Liquid

PITOBAR flow sensors are widely used for liquid flow measurement in horizontal or vertical pipe.

In horizontal pipes the PITOBAR is to be mounted in the center line or below.

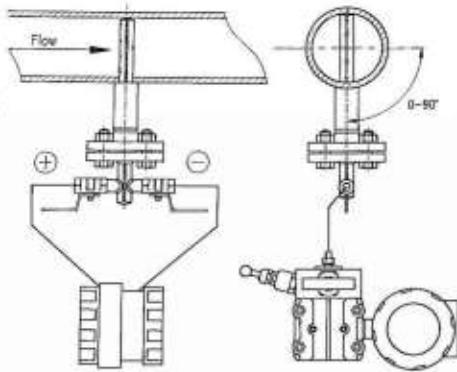

The differential pressure transmitter shall be mounted below the PITOBAR to let air escape into the main pipe line.

If the liquid is not clean the flow sensor can be purged through two purge connections as an option.

Gas

The PITOBAR flow sensor measures air or gasses in round pipes or rectangular ducts in horizontal or vertical pipe runs. In horizontal pipes the PITOBAR is to be mounted in sensor line of above. The transmitter shall be mounted above the PITOBAR to let condensate escape into the main pipe.

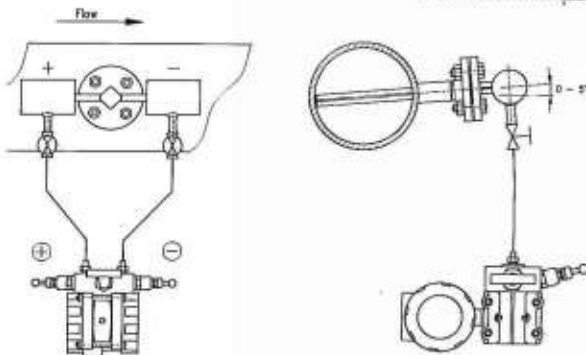
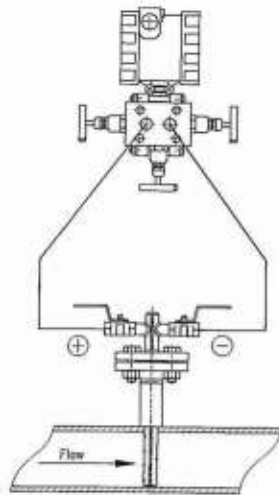

Steam

PITOBAR flow sensors for steam flow are supplied with condensing chambers for horizontal or vertical pipes. The PITOBAR is mounted horizontally (on the side of the pipe). Preferably with a slope up to 5 degr. above center line allowing condensate in the sensor to flow back into the main pipe.

Retractable

PITOBAR flow sensors are available with retractable mechanism to withdraw the sensor from the process under pressure. The sensor can be cleaned or inspected before insertion into the process.

Purge connection

If the PITOBAR is used for a fluid with impurities it is forseen with purge connections. The PITOBAR can be purged continuously or periodically with a gas or a liquid compatible with the process fluid.

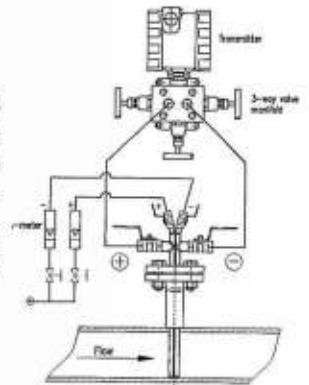

Secondary Instrumentation

1. The simplest solution for flow reading is the differential pressure gauge, scales in flowing units. This is only applicable for local reading.
2. When remote indication or control is needed, a differential pressure transmitter is required. The flow related differential pressure is transformed into an electronic signal, 4 - 20 mA. The signal is processed in a PLC, PID controller or flow computer, depending on the application. It is possible to make a mass flow measurement with a PITOBAR for compressible fluids. The secondary instrumentation will then consist of the following equipment:
 - Differential pressure transmitter
 - Pressure transmitter
 - Temperature transmitter
 - Flow computer.

However, many Dp-transmitters now include compensation for pressure and temperature which omits the necessity for a pressure transmitter. The temperature sensor is still required.

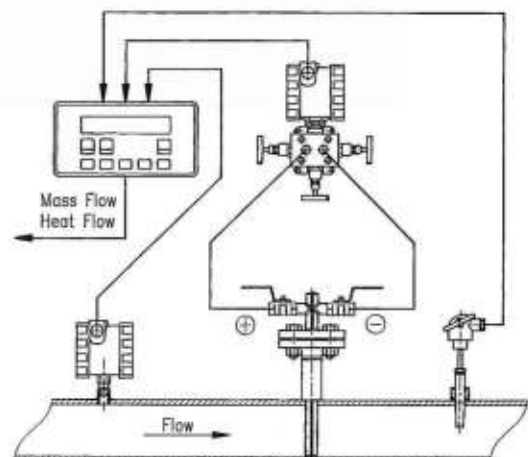

Coding of PITOBAR Types

	DK200, DK201, DK202 DK203, DK250, DK251 DK252, DK253, DK261*	PC450, PC455	PC550, PC555
BOTTOM SUPPORT			
A	Excl. bottom support	Excl. bottom support	Excl. bottom support
B	With bottom support	With bottom support	With bottom support
PITOT TUBE MATERIAL			
0	Stainless steel AISI 316	Stainless steel AISI 316	PVDF
1	Hastelloy	-	-
2	Incoloy	-	-
3	254 SMO	-	-
4	Heat resistant steel CrMo - 10CrMo910	-	-
5	Heat resistant steel CrMo - 13CrMo44	-	-
9	Other, please specify	Other, please specify	Other, please specify
MOUNTING PARTS			
0	Carbon steel	Carbon steel	PVDF
1	Stainless steel AISI 316	Stainless steel AISI 316	-
2	Heat resistant steel 13CrMo44	-	-
3	Heat resistant steel 10CrMo910	-	-
9	Other, please specify	Other, please specify	Other, please specify
FLANGE SIZE AND RATING			
10	DN 32 PN 16	DN 80 PN 16	DN 80 PN 16
11	1 1/2" 150 lbs RF	3" 150 lbs RF	3" 150 lbs RF
20	DN 32 PN 40	DN 80 PN 40	-
21	1 1/2" 300 lbs RF	3" 300 lbs RF	-
30	DN 40 PN 100	-	-
31	1 1/2" 600 lbs RF	-	-
32	1 1/2" 600 lbs RTJ	-	-
40	DN 40 PN 160	-	-
41	1 1/2" 900 lbs RF	-	-
42	1 1/2" 900 lbs RTJ	-	-
50	DN 40 PN 250	-	-
51	1 1/2" 1500 lbs RF	-	-
52	1 1/2" 1500 lbs RTJ	-	-
60	DN 40 PN 320	-	-
70	DN 25 PN 400	-	-
71	1 1/2" 2500 lbs RF	-	-
72	1 1/2" 2500 lbs RTJ	-	-
90	Other, please specify	Other, please specify	Other, please specify
INSTRUMENT CONNECTION			
10	1/2" BSP	1/2" BSP	1/2" BSP
11	1/2" NPT	1/2" NPT	1/2" NPT
12	Weld ends Ø 21,3	-	-
13	Other, please specify	Other, please specify	Other, please specify
PIPE POSITION			
H	Horizontal pipe line	Horizontal pipe line	Horizontal pipe line
V	Vertical pipe line	Vertical pipe line	Vertical pipe line
LENGTH OF MOUNTING PARTS			
130	130 mm, standard	130 mm, standard	130 mm, standard
150	150	150	150
	XXX	XXX	XXX
SPECIAL APPLICATION			
S	1/4" purge connection	1/4" purge connection	1/4" purge connection

* Type 261 is an all welded construction, no flanges. Example of an ordered PITOBAR using the above codes: DK200-A0010.10H.130.S type DK200 PITOBAR, probe in stainless steel, mounting parts in carbon steel, flange size and rating DN 32 PN 16, instrument connection 1/2" BSP, horizontal pipe line, length of mounting parts 130 mm and purge connection.

EmcoControls