

EMCO Thermowell Type 4 for Weld-in Connection

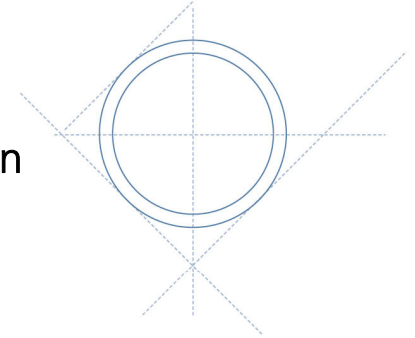

Principle

EMCO thermowell type 4 is used for mechanical and corrosive protection of temperature sensing instruments such as bimetal thermometers, thermocouples, and RTD's with a maximum outer diameter of 3, 6, 8, 10, 12, 13 mm.

Construction

EMCO thermowells type 4 with an outer diameter from 18 to 32 mm are designed and manufactured according to DIN 43772 Form 4.

Material : W.Nr. 1.4571 (AISI 316Ti), Heat resistance steels such as 1.5415 (16Mo3, F1), 1.7335 (13CrMo4-5, F11), 1.7380 (10CrMo9-10, F22), 1.4961 (X8CrNiNb1613), Inconel and other exotic materials on request.

Outer diameter : 18 mm, 24 mm, 26 mm, h7, 32 mm h11

Pressure rating : according to standard, see overleaf

Dimensions :

Type	L	U	G	N	F2	F3	d1
118	110	65	105	M14x1,5	18	9,0	3,5
218	110	73	105	M14x1,5	18	9,0	3,5
318	140	65	135	M14x1,5	18	9,0	3,5
418	200	65	195	M14x1,5	18	9,0	3,5
518	200	125	195	M14x1,5	18	9,0	3,5
618	260	125	255	M14x1,5	18	9,0	3,5
124	110	65	105	M18x1,5	24	12,5	7
224	110	73	105	M18x1,5	24	12,5	7
324	140	65	135	M18x1,5	24	12,5	7
424	170	133	165	M18x1,5	24	12,5	7
524	200	125	195	M18x1,5	24	12,5	7
624	200	65	195	M18x1,5	24	12,5	7
724	260	125	255	M18x1,5	24	12,5	7
824	410	275	405	M18x1,5	24	12,5	7
126	110	65	105	½" BSP	26	12,5	7
226	110	73	105	½" BSP	26	12,5	7
326	140	65	135	½" BSP	26	12,5	7
426	200	65	195	½" BSP	26	12,5	7
526	200	125	195	½" BSP	26	12,5	7
626	260	125	255	½" BSP	26	12,5	7
726	410	275	405	½" BSP	26	12,5	7

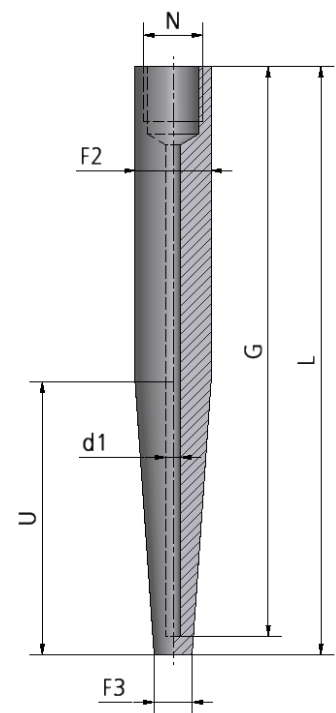

Larger well outside diameter and bore on request

0-10-014-1e

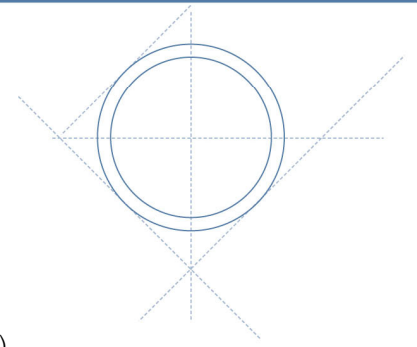

Well form : Taper

Tip thickness : 4,5 mm

Instrument connection : M 14 x 1,5 (Ø 18 mm wells), M 18 x 1,5 (Ø 24 mm wells)
 ½" BSP (Ø 26 mm wells)

Accessories : Brass plug

Maximum fluid velocity

Gas and super heated steam : 60 m/s

Liquid : 5 m/s

Maximum design pressure

Gas, steam and liquid : 450 bar

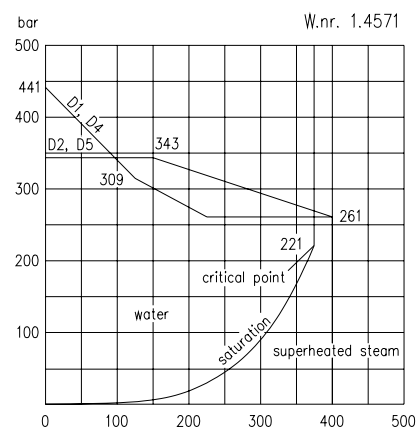
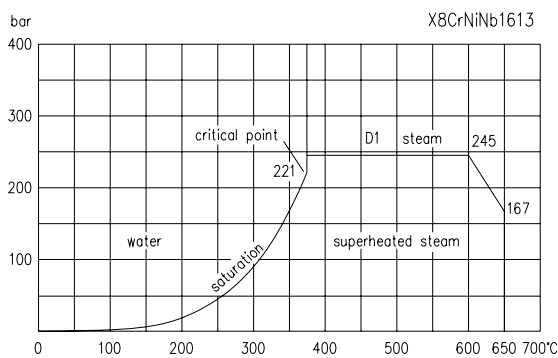
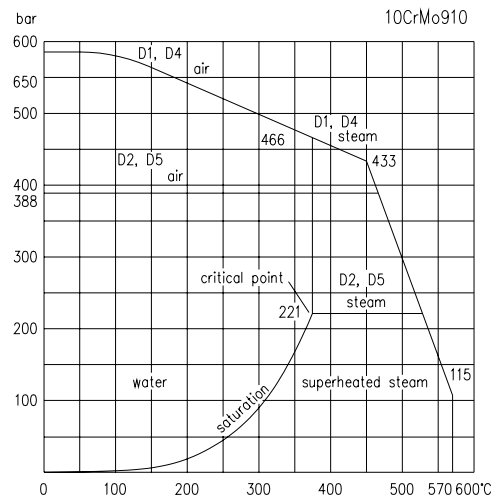
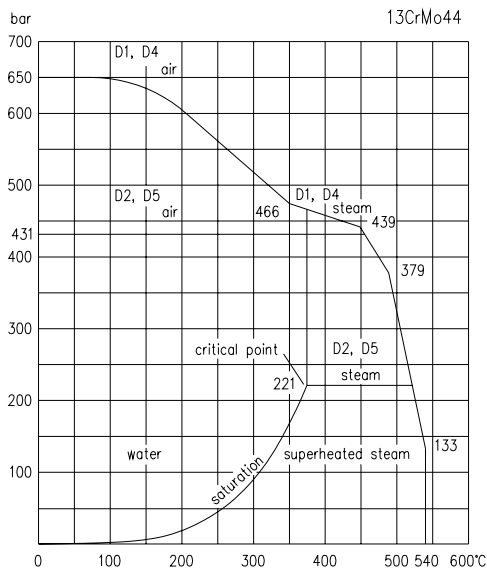

Certificates : Material certificate according to EN 10204-3.1

0-10-014-1e